

VARIOUS PIR ARRAYS

The various Fresnel Technologies lens arrays shown in the accompanying data sheets are intended to be used in passive infrared motion detector devices. They are optimized for dual-element pyroelectric detectors. They are normally used with the grooved side facing the pyroelectric detector, and curved at a radius about the sensitive area of the detector. The detector position should be as shown, and centered left-right (see Figures 1–9).

The overall dimensions of the arrays are as shown in the data sheets. Their usual thickness is 0.015" \pm 0.004" (0.38 mm \pm 0.1 mm). Border width is also as shown in the figures. Centering is held to 0.015" (0.38 mm) in both directions, except for the EWA 0.3 GI V1, where it is held to 0.005" (0.12 mm).

Fresnel Technologies, Inc. is the premier manufacturer of Fresnel lens arrays. We have led the industry in the development of new lenses and materials to advance the state of the art of passive infrared motion detection. Our lenses and lens arrays have been incorporated into most passive infrared devices using refractive optics since 1976. Our quality standards are the highest in the industry. Surface finish and inclusions are such that no defect is visible at a distance of 3 feet (1 meter) under ordinary light. There are no functional flaws in our products whatsoever. Our POLY IR® infrared-transmitting materials are the best available in stiffness and in transmittance in the 8 to 14 μ m region. Active lens segments are made from our acclaimed and patented LODIFF® lens patterns. The LODIFF® lens is covered under U.S. pat. Re. 35,534. Patents have been issued or are pending on several of the designs shown.

The various lens arrays shown in the data sheets are:

WIDE ANGLE ARRAYS

WA 0.9 GI 6 V1
WA 0.9 GI 6 V2
WA 0.9 GI T1
WA 1.13 GO 14 V1

EXTRA WIDE ANGLE ARRAYS

EWA 0.3 GI V1
EWA 1.35 GI V1

ANIMAL ALLEY ARRAY

AA 0.53 GI V1

The mounting configuration for each array can be derived from a combination of its name and its data sheet. The first portion of the name (e.g. WA) denotes the classification of the array (in the case of WA, wide angle). The second portion denotes the focal length (i.e., the distance from the lens array to the active elements of the pyroelectric detector). GI or GO indicates that the array is designed to be used with its grooves toward or away from the detector, respectively. If there is a number after GI or GO, it indicates the number of degrees of downward tilt. If there is no number in that position, the array is meant to be used with no tilt. The final portion is the "version" or "type" of the particular array within its classification and focal length. Each data sheet indicates the vertical position of the centerline of the pyroelectric detector with respect to the lens array's border, and also shows the preferred mounting height and downward tilt.

The data sheets of Figures 1–9 illustrate the zone patterns for the arrays. The figures postulate a dual-element detector with 110° coverage both up-down and left-right, amplifier gain of about 5,000, a mounting height of 3.3 feet (1 meter) for the animal alley lens array and the EWA 0.3 GI V1 and 6.8 feet (2.1 meters) for the others, and downward tilts as shown in each array's designation. Other configurations (smooth side toward the detector, curved at other radii, tilted at other angles, etc.) can be used as well, but the zone patterns illustrated in Figures 1–9 will not apply.

fresnel
technologies inc.

101 WEST MORNINGSIDE DRIVE
FORT WORTH, TEXAS 76110
(817) 926-7474
FAX: (817) 926-7146

WIDE ANGLE ARRAY

WA 0.9 GI 6 V1

FRONT VIEW:

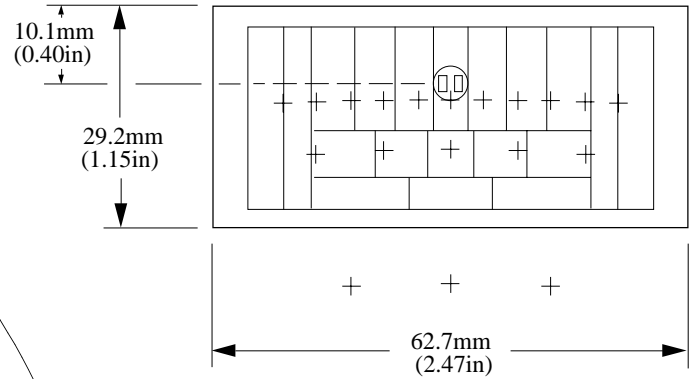

TOP VIEW:

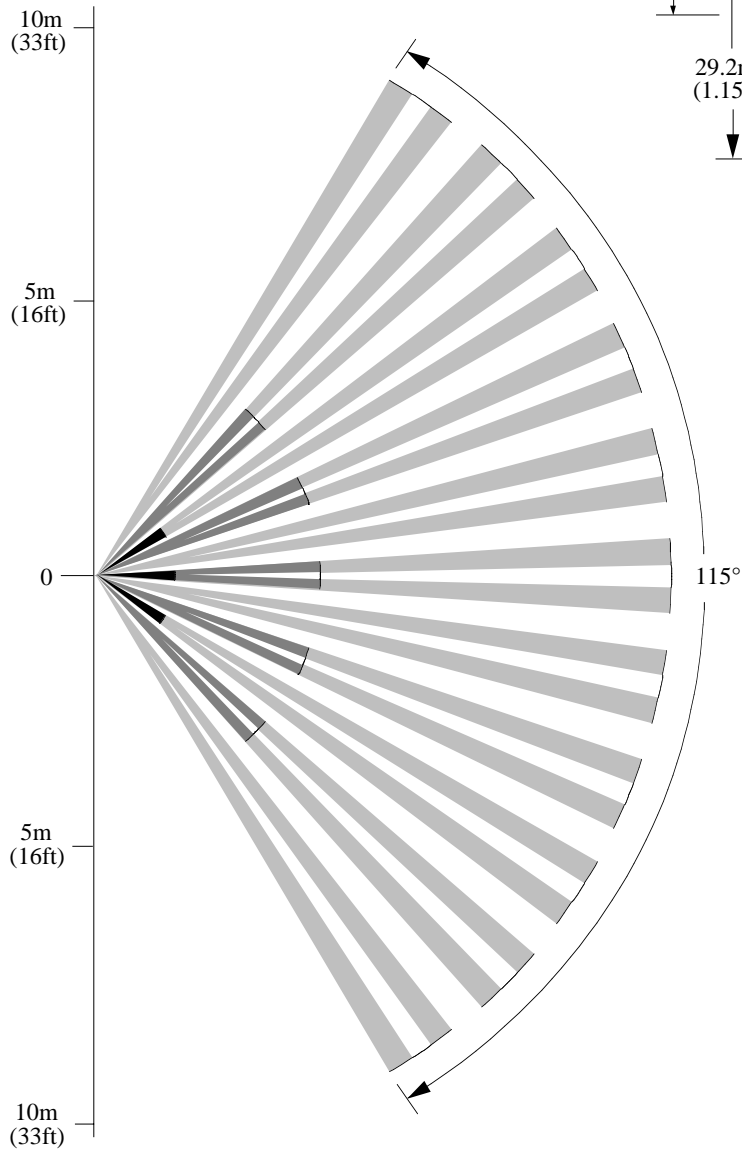

SIDE VIEW:

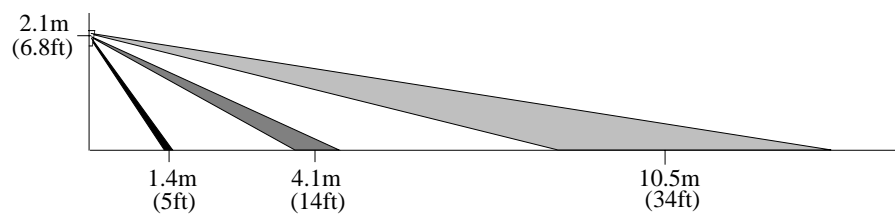

WIDE ANGLE ARRAY

WA 0.9 GI 6 V2

FRONT VIEW:

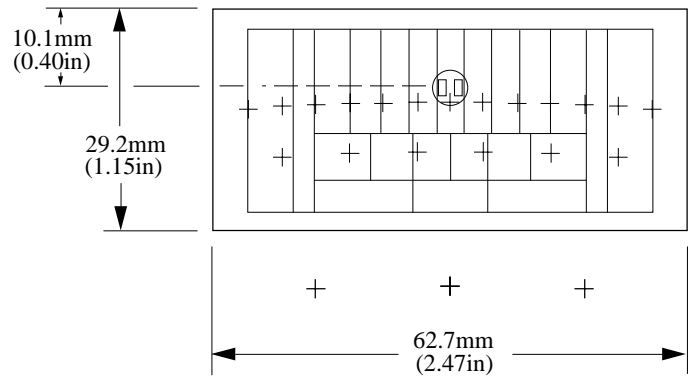

TOP VIEW:

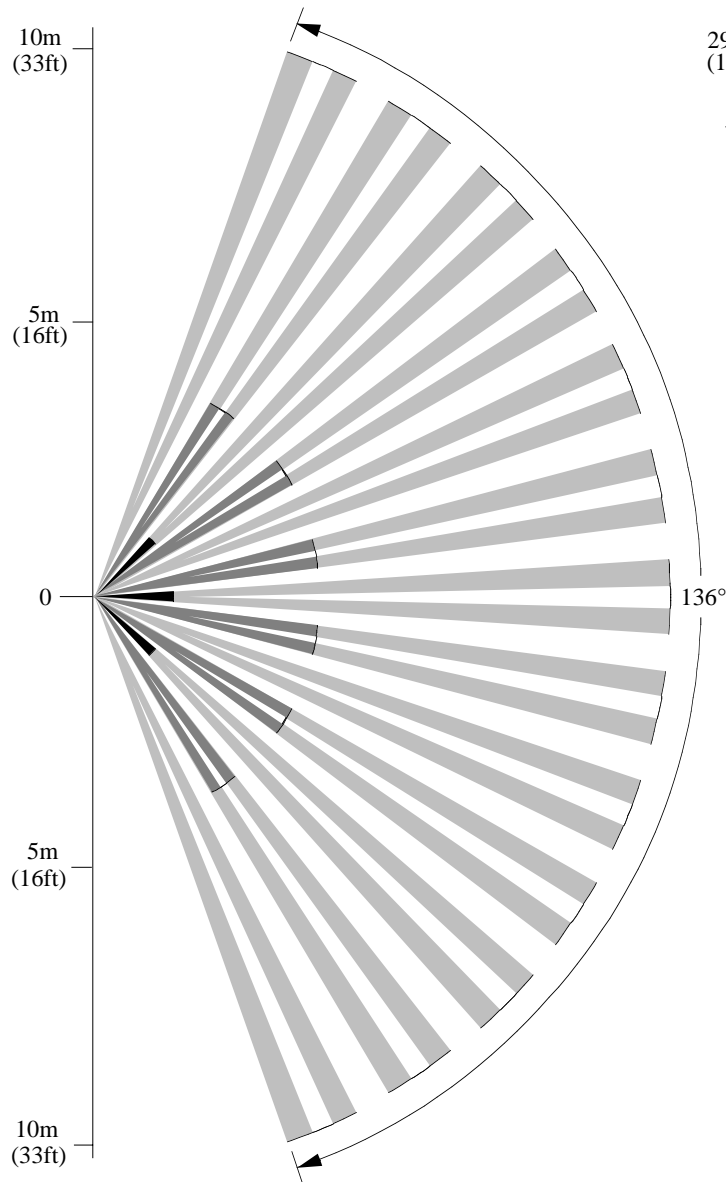

SIDE VIEW:

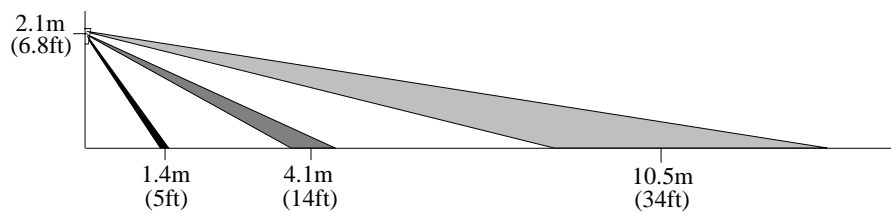

WIDE ANGLE ARRAY

WA 0.9 GI T1

TOP VIEW:

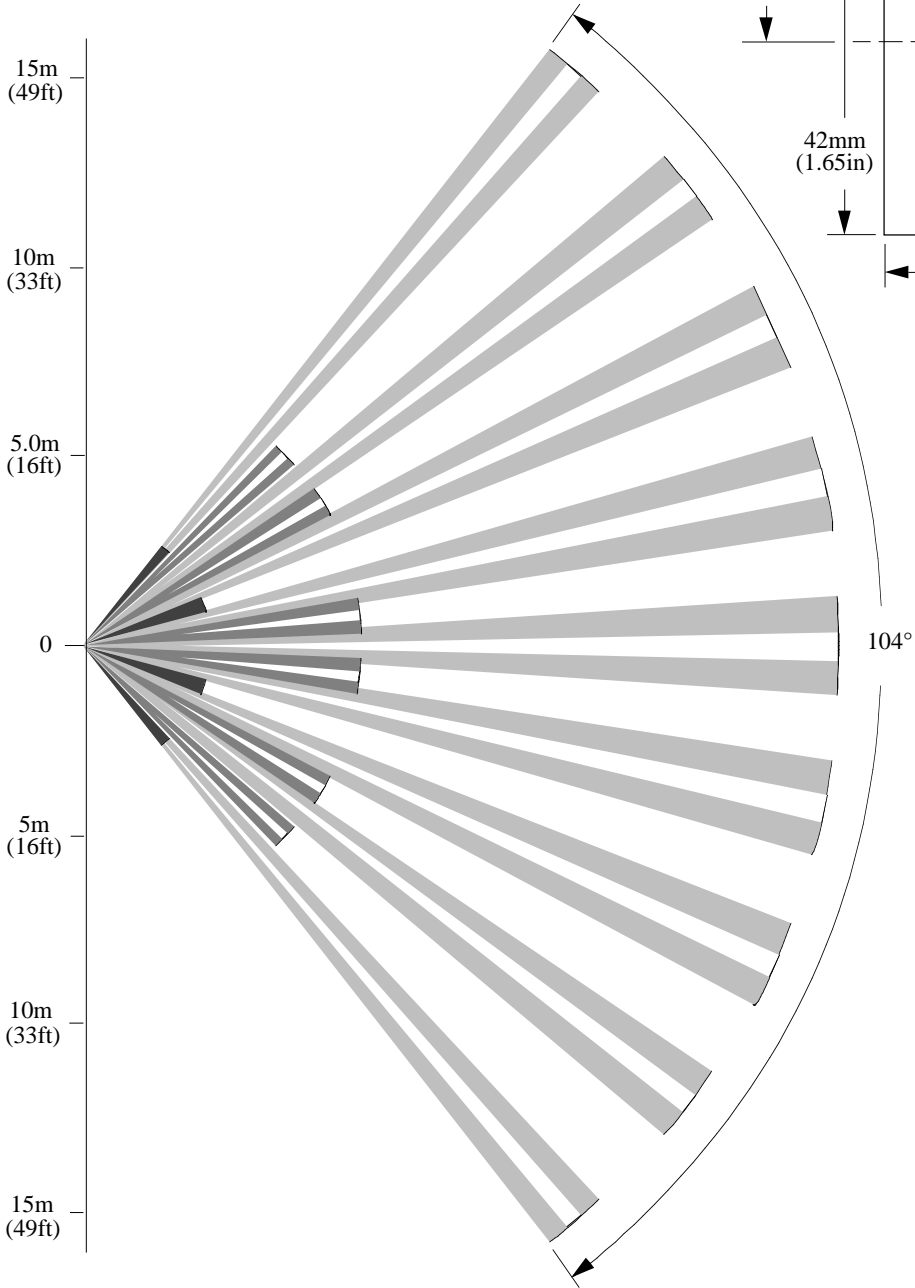

FRONT VIEW:

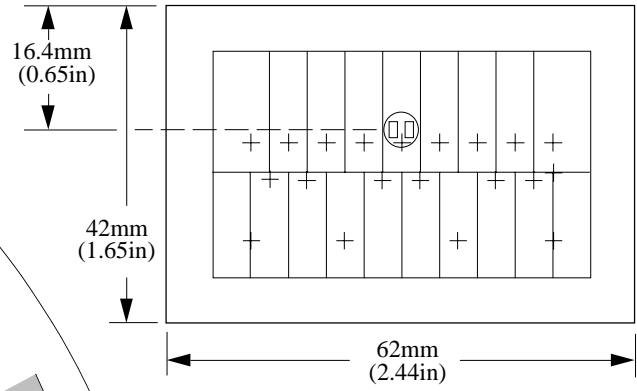

SIDE VIEW:

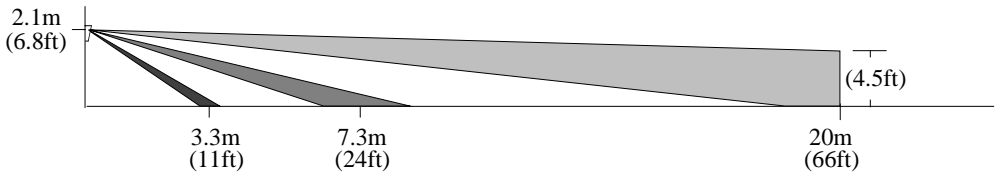

WIDE ANGLE ARRAY

WA 1.13 GO 14 V1

TOP VIEW:

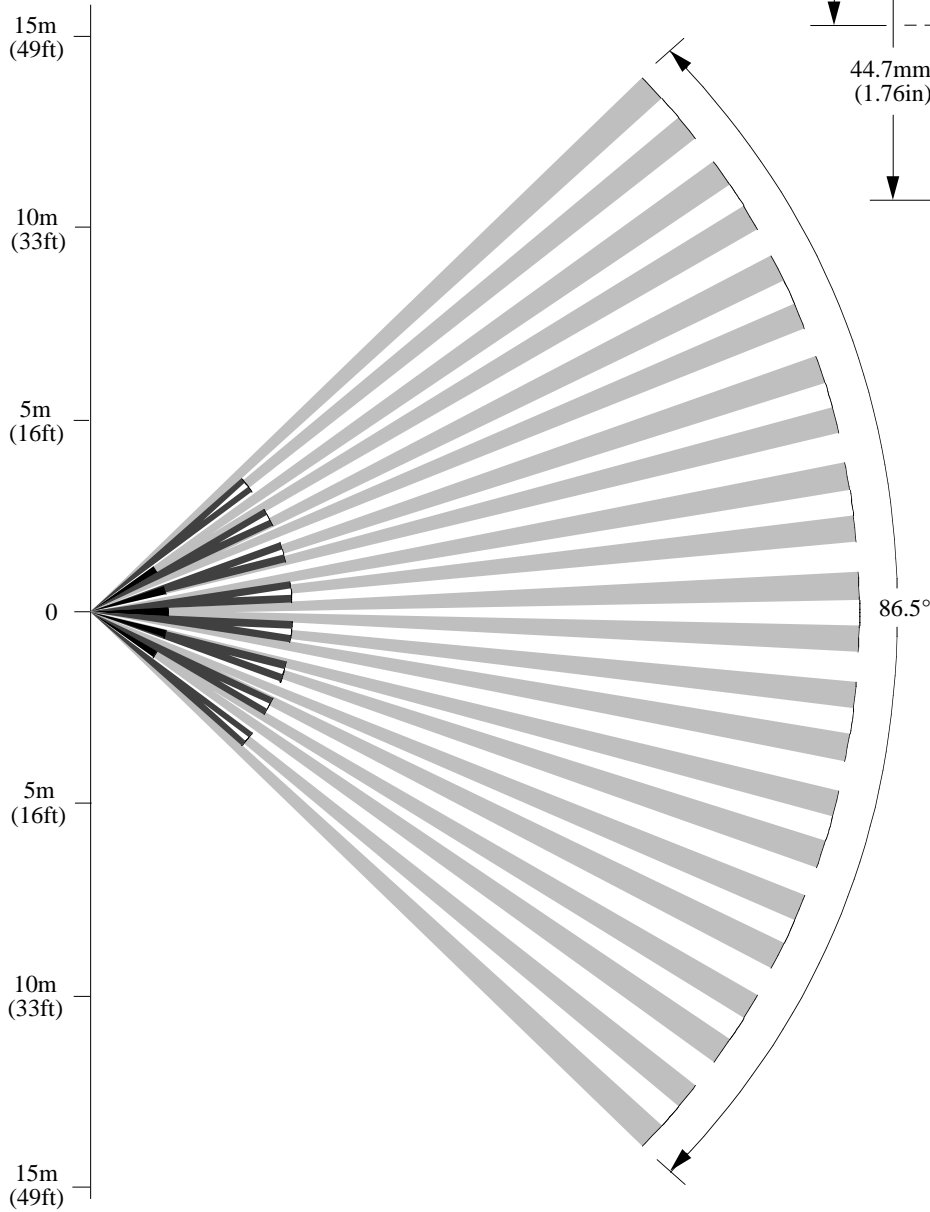

FRONT VIEW:

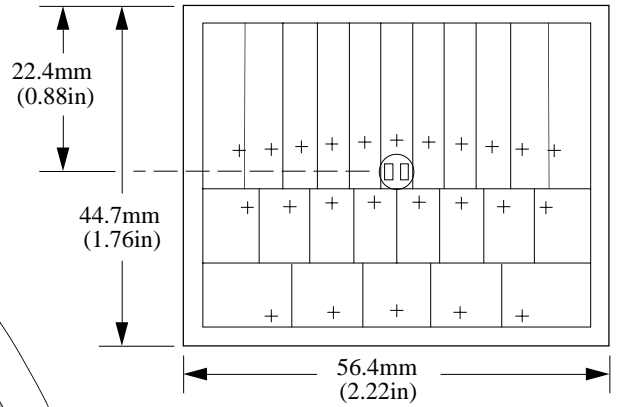

SIDE VIEW:

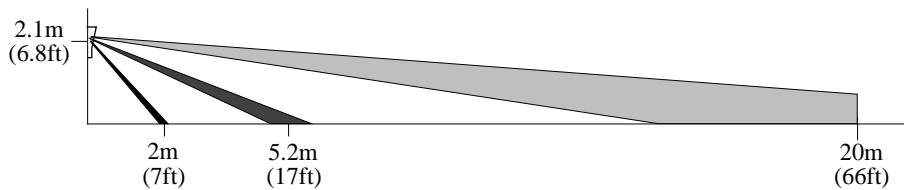

EXTRA WIDE ANGLE ARRAY

EWA 0.3 GI V1

TOP VIEW:

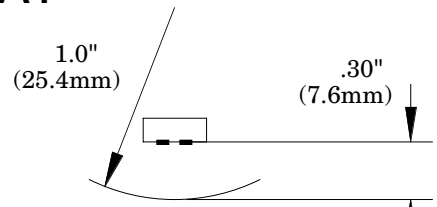

FRONT VIEW:

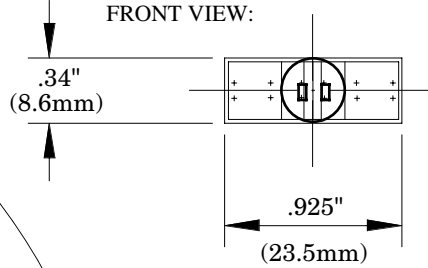

Note: Lensed area is 0.300" x 0.885"
Maximum die-cut size is 0.635" x 1.220"

TOP VIEW:



SIDE VIEW:

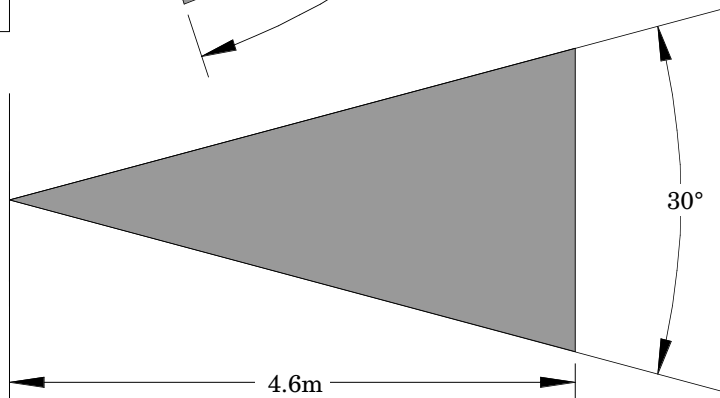

EWA 1.35 GI V1

"Beam" diagram

TOP VIEW:

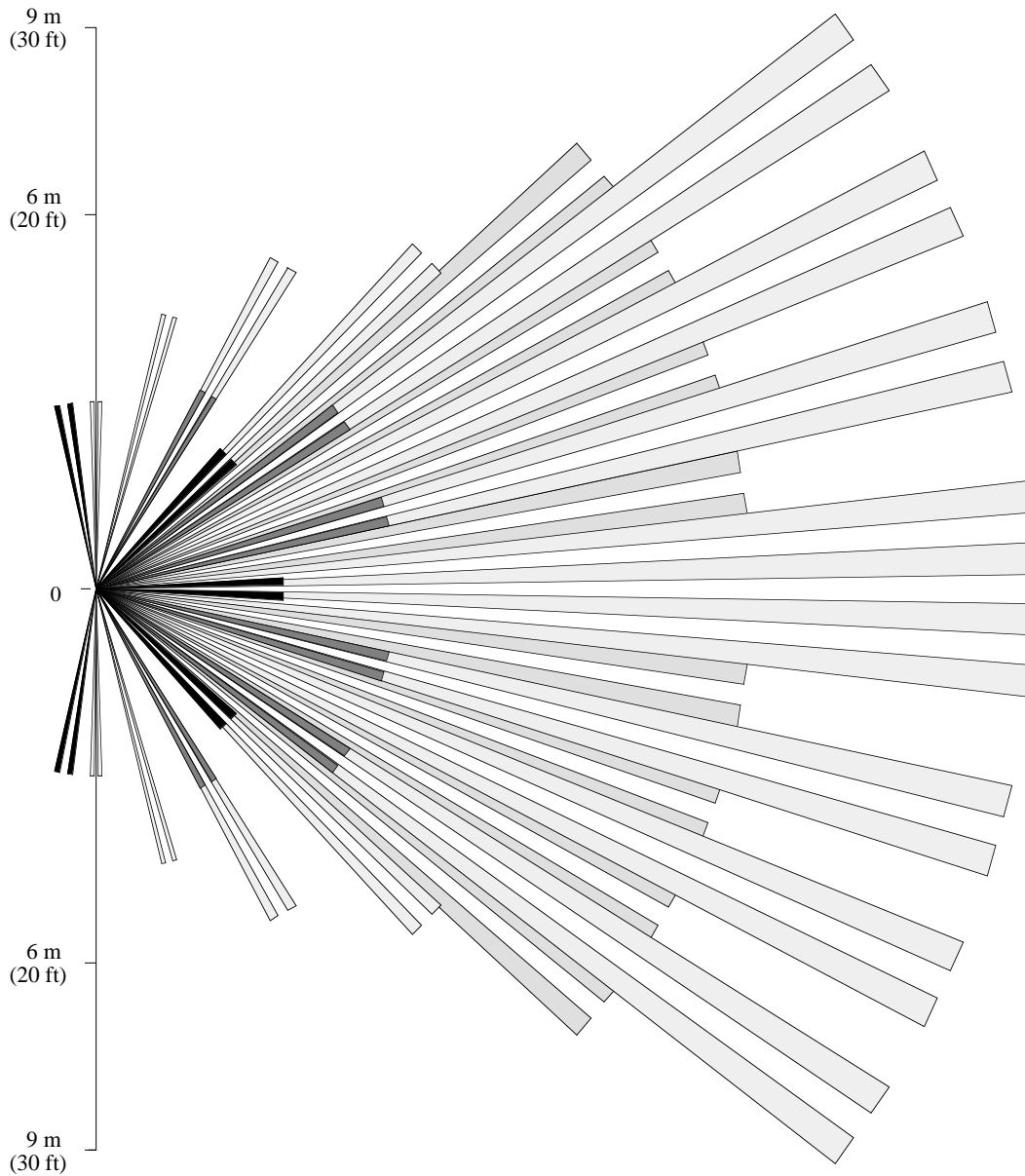

SIDE VIEW:

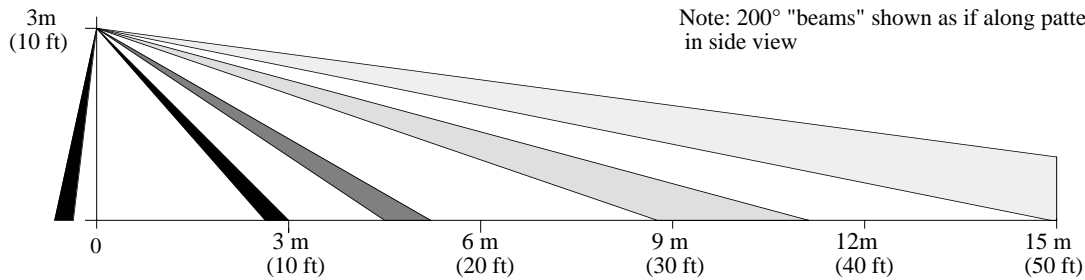

Note: 200° "beams" shown as if along pattern centerline in side view

EWA 1.35 GI V1

Mounting details

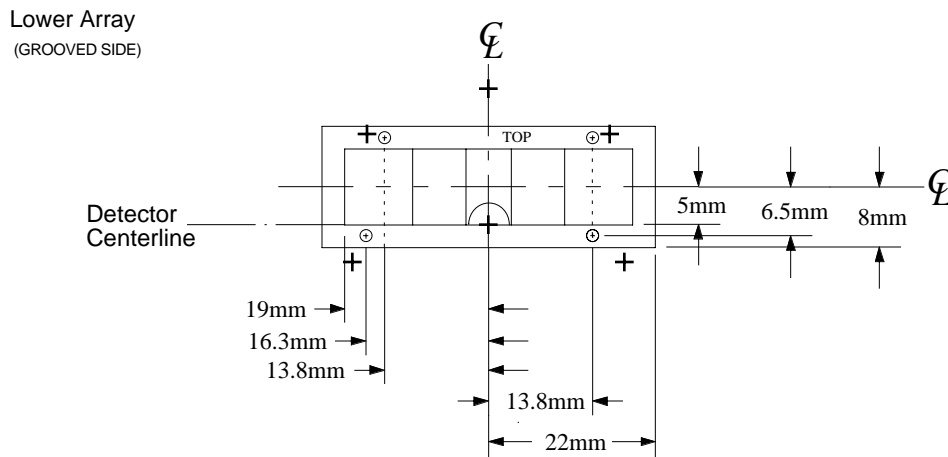
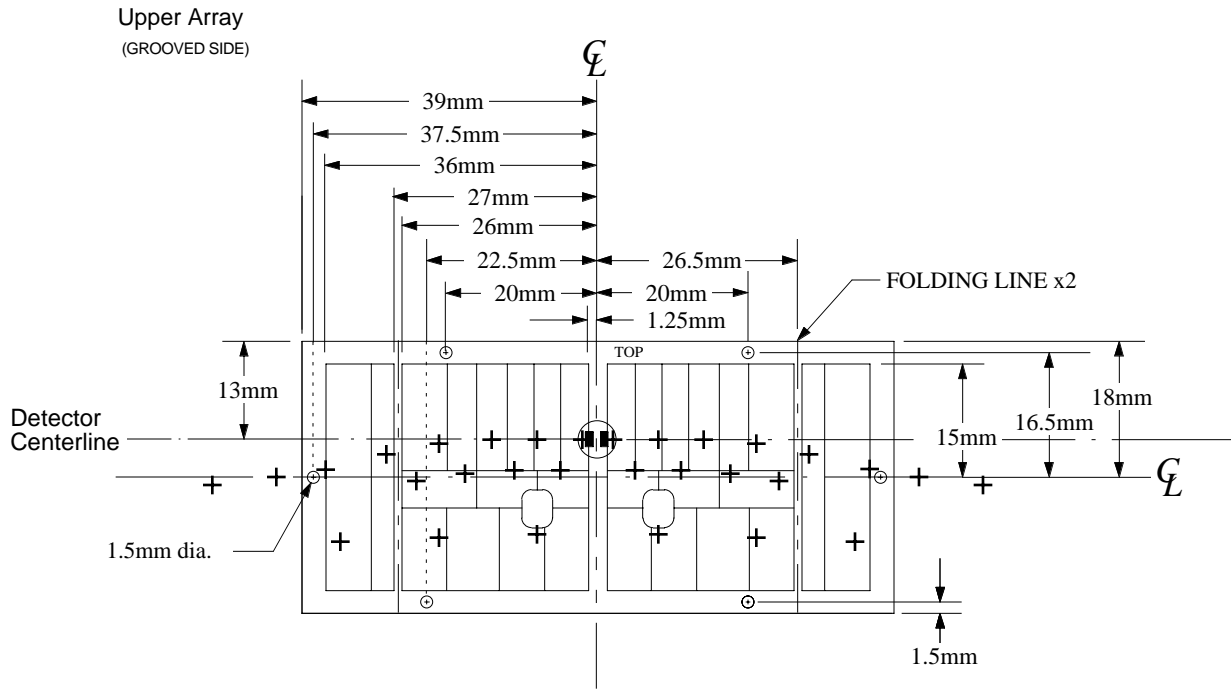

Scale: 1 to 1

fresnel technologies inc.

© 2000

101 W. MORNINGSIDe DR. FORT WORTH, TX 76110, U. S. A. (817) 926-7474, FAX: (817) 926-7146

Drawn By: Brian Dow

EWA 1.35 GI V1

Detector location

FRONT VIEW:

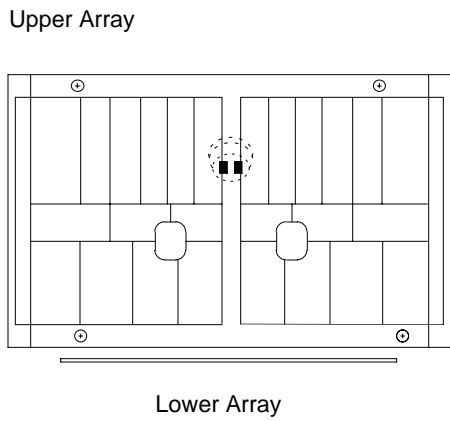

SIDE VIEW:

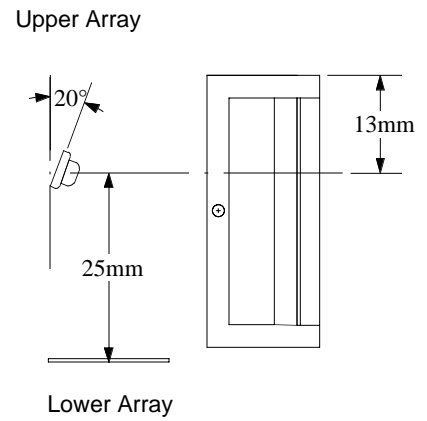

TOP VIEW:

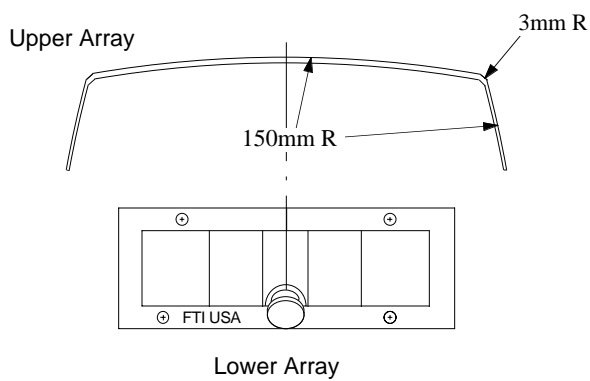

Scale:1 to 1

fresnel technologies inc.

© 2000

101W. MORNINGSIDE DR. FORT WORTH, TX 76110, U. S. A. (817) 926-7474, FAX:(817)926-7146

Drawn By: Helen Dow

ANIMAL ALLEY ARRAY

AA 0.53 GI V1

TOP VIEW:

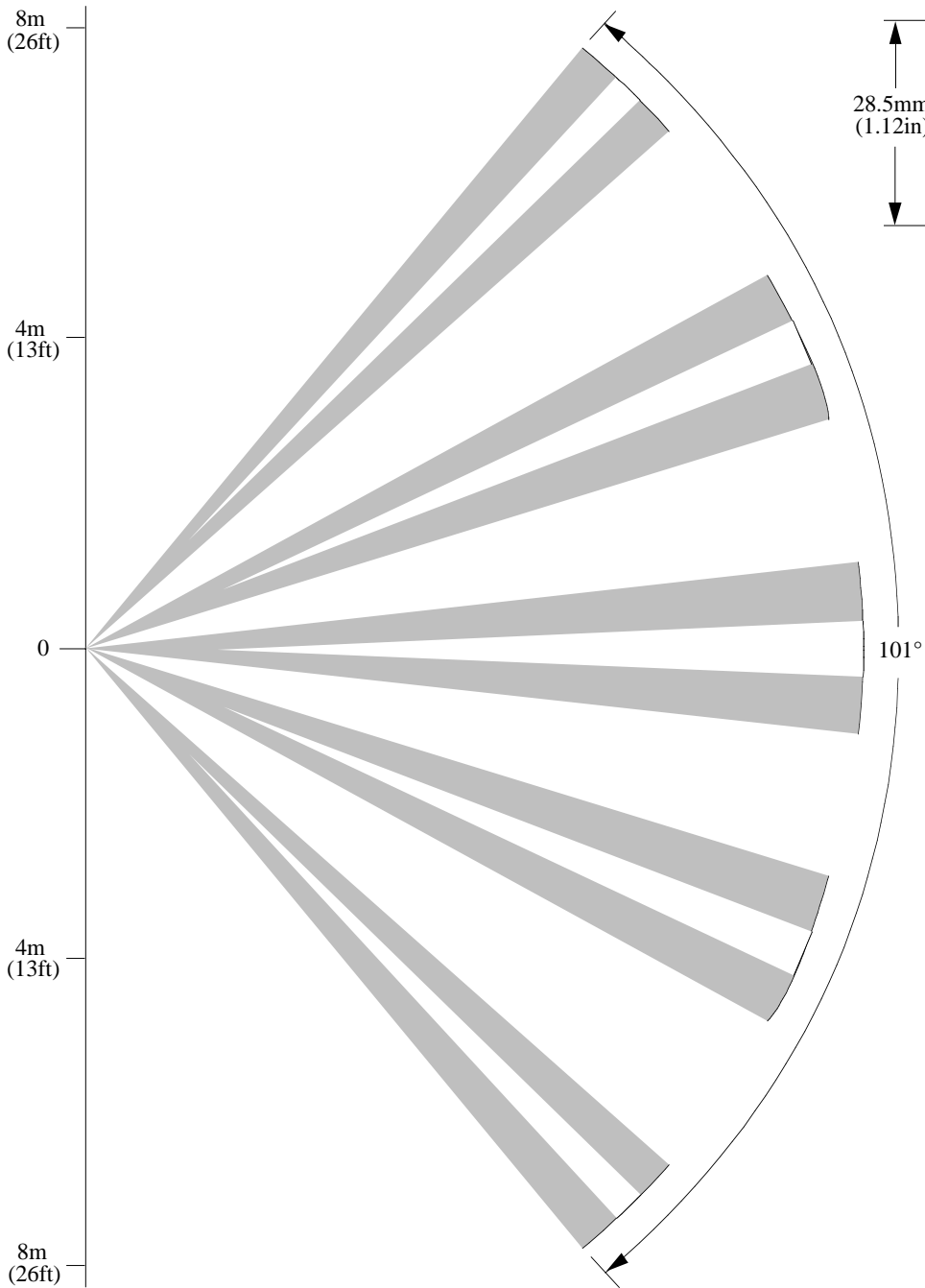

FRONT VIEW:

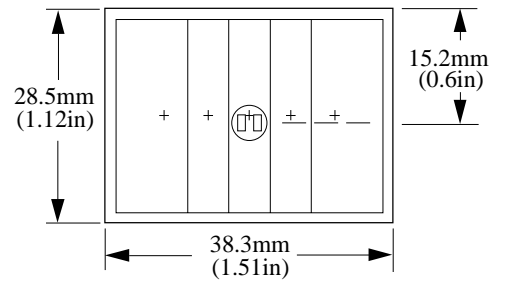

SIDE VIEW:

